



CITY OF ALVIN  
Fire Marshal's Office  
801 East South Street  
Alvin, Texas 77511  
Office (281) 331-7688 FAX (281) 331-9713



---

# Contractor Packet

## TABLE OF CONTENTS

- Notice of Information
- General Requirements
- Fire Protection System(s) Requirements
- Fire Prevention and Protection Permit Fees
- ISO Plan Review Requirements
- Permit Application
- Suppression and Detection System Plan Submittals
- Sprinkler System Underground Checklist
- Sprinkler System Aboveground Checklist
- Fire Department Connection Sign Requirements
- Fire Lane Requirements
- Fire Alarm Checklist
- Commercial Cooking Suppression Checklist
- Paint Booth Suppression Checklist
- Fire Pump Checklist
- Knox Box Sign Requirements



**CITY OF ALVIN**  
**Fire Marshal's Office**  
801 East South Street  
Alvin, Texas 77511  
Office (281) 331-7688 FAX (281) 331-9713



---

## NOTICE OF INFORMATION

This letter of notice is to inform prospective builders, owners and contractors who are planning to build within the City of Alvin, the proper requirements for system installations and testing needed by the Fire Marshal's Office. This notice shall serve for informational purposes only, actual installation requirements and testing may vary.

### PLAN REVIEW

1. The City of Alvin uses the International Fire Code (IFC) 2018 *edition*  
Current amendments to this code can be located at <http://www.municode.com>
2. All Fire Sprinkler plans must be reviewed by ISO prior to submittal to this office.
3. Plan submittal for fire suppression and detection systems shall be provided for approval. Two (2) hard copies and one (1) electronic copy in .pdf format are required. The two hard copies will be returned. One stamped set **MUST** remain on site at **ALL TIMES**.
  - a. Fire sprinkler plans shall include hydraulic calc's with a 10% safety factor, cut sheets, copies of license and insurance and completed set of drawings for the proposed installation.
  - b. Fire alarm plans shall include battery calc's, cut sheets, copies of license and insurance and completed set of shop drawings for the proposed installation.
4. All plans must be complete and legible. Any incomplete submittals will be returned.
5. Any plans that are returned with corrections will be provided a list of needed corrections. Resubmitted plans shall be of the same style and returned stating corrections.
6. A current copy of licenses and proof of insurance, naming the City of Alvin as certificate holder shall be provided for all licensed companies.

### BUILDING PLANS

1. Approved vehicle access shall be provided by either temporary or permanent roads, capable of supporting vehicle loading under all weather conditions. Vehicle access shall be maintained until permanent fire apparatus access roads are available.
2. An approved water supply for fire protection, either temporary or permanent, shall be made available as soon as combustible material arrives on the site.
3. The approved and stamped civil site plans shall be submitted with the building plans.
4. The approved stamped set of plans shall remain on site at all times.



**CITY OF ALVIN**  
**Fire Marshal's Office**  
801 East South Street  
Alvin, Texas 77511  
Office (281) 331-7688 FAX (281) 331-9713



---

## **General Requirements**

### **General Requirements**

1. Temporary site address shall be displayed plainly legible and visible from the street or road fronting the property. These numbers shall contrast with their background. Numbers shall be a minimum of 12 inches high with a minimum stroke width of 0.5 inch facing addressed street.
2. All fire department inspection forms and permits shall be kept in a permit packet on the job site until final inspection.

### **Vertical Construction Approval**

3. All permanent fire hydrants and fire lane access roadways shall be installed and approved prior to vertical construction of any building or structure, unless otherwise approved by the Fire Marshal and Building Official.
4. A fire hydrant confidence test shall be conducted to verify ability to meet the Needed Fire Flow (see Appendix B in the 2018 edition of the International Fire Code for further info) for the building or structure.
5. An approved water supply for fire protection shall be made available as soon as combustible material arrives on the site.

### **Furniture, Fixture and Equipment Placement (FF&E) Approval**

6. All required fire protection systems must be installed and approved prior to any stock and/or equipment being installed within a building.
7. An "OK to Stock Meeting" must be schedule through the Fire Marshal's Office.
8. Written approval must be given prior to any stock and/or equipment to be placed within the building.

### **Outdoor Burning**

9. Approval shall be obtained from the Texas Commission on Environmental Quality and obtain a permit from the Alvin Fire Marshal's Office prior to any outdoor burning.
10. A Copy of the State permit (if applicable) and any other required documents shall be presented to the fire code official with the Outdoor Burn Permit application.
11. The location for open burning shall not be less than 300 feet from any structure, and provisions shall be made to prevent the fire from spreading to within 300 feet of any structure.
12. Temporary fencing shall be provided around the pit after hours.

### **Temporary Fuel Storage Tanks**

13. A permit shall be obtained from the Alvin Fire Marshal's Office prior to placement of any above ground fuel dispensing tanks or containers on construction sites.
14. Temporary storage tank(s) shall comply with chapter 50 of the International Fire Code and all applicable sections of chapter 57 of the International Fire Code and NFPA Standards.



---

### **Temporary Heating Devices**

15. Temporary heating devices shall be listed and labeled. Installation, maintenance, and use of temporary heating devices shall be in accordance with the terms of the listing.
16. Refueling operations shall be conducted only when the appliance is allowed to cool, prior to refueling.
19. Clearance to combustibles from temporary heating devices shall be maintained in accordance with the labeled equipment. When in operation, temporary heating devices shall be fixed in place and protected from damage, dislodgement, or overturning in accordance with the manufacturer's instructions.
20. The use of temporary heating devices shall be supervised and maintained only by competent personnel.

### **Precautions against Fire**

21. Smoking shall be prohibited except in approved areas. Signs shall be posted in conspicuous locations. In approved areas where smoking is permitted, approved noncombustible ashtrays shall be provided.
22. Combustible debris shall not be accumulated within buildings. Combustible debris, rubbish, and waste material shall be removed from buildings at the end of each shift of work. Combustible debris, rubbish, and waste material shall not be disposed of by burning on the site.
23. Materials susceptible to spontaneous ignition, such as oily rags, shall be stored in a listed disposal container.
24. Where required by the code official for building demolition that is hazardous in nature, qualified personnel shall be provided to serve as an on-site fire watch. The sole duty of fire-watch personnel shall be to watch for the occurrence of fire.
25. Operations involving the use of cutting and welding shall be done in accordance with IFC Chapter 35.
26. Temporary wiring for electrical power and lighting installations used in connection with the construction, alteration, or demolition of buildings, structures, equipment, or similar activities shall comply with NFPA 70 National Electrical Code.

### **Flammable and Combustible Liquids**

27. Ventilation shall be provided for operations involving the application of materials containing flammable solvents.
28. Flammable and combustible liquid storage areas shall be maintained clear of combustible vegetation and waste materials. Such storage areas shall not be used for the storage of combustible materials.
29. Sources of ignition and smoking shall be prohibited in flammable and combustible liquid storage areas. Signs shall be posted.
30. Class I and II liquids shall be kept in approved safety containers.
31. Leaking vessels shall be immediately repaired or taken out of service and spills shall be cleaned up and disposed of properly.



---

### **Owner's Responsibility for Fire Protection**

32. The owner shall designate a person to be the Fire Prevention Program Superintendent who shall be responsible for the fire prevention program and ensure that it is carried out through completion of the project. The fire prevention program superintendent shall have the authority to enforce the provisions of these guidelines and other provisions as necessary to secure the intent of this chapter. Where guard service is provided, the superintendent shall be responsible for the guard service.
33. The fire prevention program superintendent shall develop and maintain an approved pre-fire plan in cooperation with the fire chief. The fire chief and the code official shall be notified of changes affecting the utilization of information contained in such pre-fire plans.
34. Training of responsible personnel in the use of fire protection equipment shall be the responsibility of the fire prevention program superintendent.
35. The fire prevention program superintendent shall determine that all fire protection equipment is maintained and serviced in accordance with this code. The quantity and type of fire protection shall be approved by the Fire Marshal.
36. The superintendent shall be responsible for supervising the permit system for hot work operations in accordance with the IFC.
37. Impairments to any fire protection system shall be in accordance with IFC 901. See *Fire Watch Guidelines* for more information
38. Temporary covering of fire protection devices. Coverings placed on or over fire protection, devices to protect them from damage during construction processes shall be immediately removed upon the completion of the construction processes in the room or area in which the devices are installed.
39. Readily accessible emergency telephone facilities shall be provided in an approved location at the construction site. The street address of the construction site and the emergency telephone number of the fire department shall be posted adjacent to the telephone.

### **Means of Egress**

40. Where a building has been constructed to a height greater than 50 feet (15 240 mm) or four stories, or where an existing building exceeding 50 feet (15 240 mm) in height is altered, at least one temporary lighted stairway shall be provided unless one or more of the permanent stairways are erected as the construction progresses.
41. Required means of egress components shall be maintained during construction and demolition.

### **Automatic Sprinkler System**

42. In buildings where an automatic sprinkler system is required by this code or the International Building Code, it shall be unlawful to occupy any portion of a building or structure until the automatic sprinkler system installation has been tested and approved.
43. Operation of sprinkler control valves shall be allowed only by properly authorized personnel and shall be accompanied by notification of duly designated parties. When the sprinkler protection is being regularly turned off and on to facilitate connection of newly completed segments, the sprinkler control valves shall be checked at the end of each work period to ascertain that protection is in service.



**CITY OF ALVIN**  
**Fire Marshal's Office**  
801 East South Street  
Alvin, Texas 77511  
Office (281) 331-7688 FAX (281) 331-9713



---

### **Portable Fire Extinguishers**

44. Structures under construction, alteration, or demolition shall be provided with not less than one approved portable fire extinguisher at each stairway on all floor levels where combustible materials have accumulated. An approved portable fire extinguisher shall be provided in every storage and construction shed. The code official is authorized to require additional approved portable fire extinguishers where special hazards exist, such as flammable or combustible liquid storage hazards.

### **Safeguarding Roofing Operations**

45. Roofing operations utilizing heat-producing systems or other ignition sources shall be performed by a contractor licensed and bonded for the type of roofing process to be performed.

46. Asphalt and tar kettles shall be operated in accordance with IFC 303.

47. Fire extinguishers for roofing operations. There shall be at least one multi-purpose portable fire extinguisher with a rating of 3A-40BC **on the roof** being covered or repaired.



---

## **FIRE SPRINKLER SYSTEMS**

1. Fire Department Connections (FDC) on all systems, except NFPA 13R and NFPA 13D shall have a single 5" storz connection with 22.5° turn down.
2. All FDC's shall have a locking cap, ordered through the Knox Company. A key wrench is required with the order, to remain in the contractors' possession.
3. All fire line feeds shall be dedicated lines with no additional water taps.
4. Where a sprinkler system is installed, it shall have a remote FDC on a separate feed to the riser and shall be located within 50 feet of the closest fire hydrant.
5. The FDC shall be located at a horizontal distance no less than one (1) foot above the total height of the structure; out of the collapse zone.
6. A double check back-flow preventor is required inside on the riser and is required to be certified and tested with a Fire Marshal present.
7. No underground pits or keystone valves are permitted.
8. All water control valves shall be protected with a chain and/or lock, as well as monitoring for tamper and water flow to a monitored fire alarm system.
9. Weather-proof horn/strobes may be installed for outside notification. It may be installed in lieu of the mechanical water gong near the sprinkler riser.
10. The inspectors test valve shall be located downstream of the water flow switch and at the most remote point.
11. Fire Department Connection signage instructions will be provided to the sprinkler company upon return of plans.
12. NO WORK may begin without prior approval of plans and the required permit has been submitted for payment.
13. All underground and aboveground piping will be hydrostatically tested to NFPA standards.
14. Underground plumbing shall be flushed prior to connection of aboveground. This shall be witnessed by the Fire Marshal's Office.
15. Sprinkler systems must be designed with a 10% safety factor of the required psi and gpm.
16. A request for inspection of fire protection system(s) shall be made through the Fire Marshal's Office.
17. The Fire Marshal's Office shall witness all final testing with the RME prior to the occupancy of the building.





---

### **FIXED FIRE SUPPRESSION SYSTEMS**

1. All FFS systems shall have local notification (audible bell) if a fire alarm system is not present.
2. All lighting within the hood assembly shall shut off upon activation.
3. The remote pull station shall be located at a distance no greater than 30 feet from the system and be located in the path of egress.
4. All gas valves shall be located below the ceiling tile.
5. A class K fire extinguisher and sign shall be mounted near the pull station.
6. All owners, occupants, and employees shall be familiar with the operation of the system and manual activation.
7. NO WORK may begin without prior approval of plans and required permit has been submitted for payment.
8. A request for inspection of fire protection system(s) shall be made through the Fire Marshal's Office.
9. The Fire Marshal's Office shall witness all final testing prior to the occupancy of the building.

### **FIRE ALARM SYSTEMS**

1. All systems shall be installed in accordance to NFPA 72 by a licensed technician.
2. All components shall meet ADA compliance.
3. Alarm panels shall be monitored to a central station.
4. Fire alarm panels that are not accessible or visible by employees shall be provided with an annunciator panel near the main entrance.
5. All zones and devices shall be identifiable and labeled in the alarm panel cover.
6. Fire alarm panels shall have a primary and secondary phone line. The primary line shall be a dedicated line.
7. Keys to the alarm panel and pull stations shall be provided to the Fire Marshal's Office to be placed in the Knox box.
8. All smoke detectors, including duct detectors will be tested using a smoke function test.
9. Smoke detectors shall recall elevator to ground level discharge.
10. Required duct smoke detectors shall be tied into the fire alarm for monitoring if one exists. The detector shall have a remote indicator and shall be capable of being reset.
11. Manual pull stations shall be installed, with audible type stopper covers, at each exit.
12. NO WORK may begin without prior approval of plans and required permit has been submitted for payment.
13. A request for inspection of fire protection system(s) shall be made through the Fire Marshal's Office.
14. The Fire Marshal's Office shall witness all final testing prior to the occupancy of the building.





---

## **FIRE PREVENTION AND PROTECTION FEES**

- (a) Permit fee. This fee is for processing permits submitted for approval, and will be paid after the plans are reviewed and prior to starting work.

**The base fee for all permits shall be \$100.00 in addition to the fees listed below.**

- (b) Reinspection permits. This fee is for conducting additional inspections due to violations found, and will be paid prior to the reinspection.

Reinspection permit .....\$25.00

- (1) Automatic fire-extinguishing system permit:

Fee per riser .....\$60.00

Fee per fire pump .....\$75.00

Fee per storage tank .....\$100.00

Fee per sprinkler head .....\$2.00

Fee per stand pipe .....\$50.00

Fee for hydrostatic testing .....\$50.00

- (2) Changes to existing automatic fire-extinguishing system permit:

Up to 10 sprinkler heads .....\$75.00

Over 10 sprinkler heads, each .....\$2.00

Over 20 sprinkler heads, hydrostatic testing fee....\$50.00

- (3) Wet chemical fire-extinguishing system permit:

Fee per system .....\$100.00

Fee per device .....\$2.00

Fee for blow-off and functional test .....\$25.00

- (4) Compresses gas permit:

Fee per system .....\$50.00

- (5) Fire alarm and detection system permit:

Fee per FACP .....\$75.00

Fee per device .....\$2.00

Fee for functional testing .....\$50.00



**CITY OF ALVIN**  
**Fire Marshal's Office**  
801 East South Street  
Alvin, Texas 77511  
Office (281) 331-7688 FAX (281) 331-9713



---

(6) Fire pump and related equipment permit:

Fee per fire pump .....\$75.00

Fee per jockey pump .....\$25.00

Fee per generator .....\$100.00

Fee per storage tank .....\$100.00

Fee for functional testing .....\$50.00

(7) Flammable and combustible liquids permit:

Pipeline fee .....\$500.00

Aboveground storage tank installation fee .....\$200.00

Aboveground storage tank repair and removal fee .....\$50.00

Underground storage tank installation .....\$400.00

Underground storage tank repair and removal .....\$100.00

(8) Hazardous material permit:

Permit fee .....\$250.00

(9) Industrial ovens permit:

Permit fee .....\$200.00

(10) LP gas permit:

Permit fee .....\$250.00

(11) Private fire hydrant permit:

Fee per hydrant .....\$25.00

Fee for hydrostatic testing .....\$50.00

(12) Spraying or dipping permit:

Fee per system .....\$100.00

Fee per device .....\$2.00

Fee for blow-off and functional test .....\$25.00



**CITY OF ALVIN**  
**Fire Marshal's Office**  
801 East South Street  
Alvin, Texas 77511  
Office (281) 331-7688 FAX (281) 331-9713



(13) Temporary membrane structures, tent, and canopy permit:

Tents and membrane structures in excess of 700 square feet and or having an occupant load of 50 or more persons and utilized as a place of assembly to include a circus, carnival, tent show, theater, skating rink, dance hall, eating/drinking facility or other place of assembly in or under which persons gather for any purpose shall not be erected, operated or maintained for any purpose without first obtaining a permit and approval from the Fire Marshal. Cost for the permit shall be .....\$100.00

(d) **Fire watch fees:**

(1) Fire watch, per hour—Minimum four (4) hours .....\$35.00

(2) Fire engine, per hour .....\$100.00

(maximum of \$600.00 for every twenty-four-hour period)

(e) **Double permit fee:** The fire code official may impose a double permit fee when it is found that a condition, activity or occupancy requiring a permit exists and no permit has been issued by the fire official.

This notice does not relieve the owner, designers, and contractors or their representatives from their individual or collective responsibility to comply with applicable provisions of the codes governing the site. This information is not to be construed as a check of every item required, including items noted or not otherwise detailed, and does not prevent the Fire Official from hereafter requiring corrections of errors.



**CITY OF ALVIN**  
**Fire Marshal's Office**  
801 East South Street  
Alvin, Texas 77511  
Office (281) 331-7688 FAX (281) 331-9713



---

## **ISO SPRINKLER PLAN REVIEW**

NEW OPTION:

### **Electronic Sprinkler Plan Review Submittals**

Electronic Plan Review submittals should be e-mailed to the following address:

[prsupport@iso.com](mailto:prsupport@iso.com)

Electronic Sprinkler Plan Review files should be formatted in files compatible with AutoCAD or ADOBE pdf. Hydraulic calculations should be submitted in pdf format. Completed reviews will be returned via **e-mail**.

**All submittals shall include underground plans to determine required flow and size of fire line feed.**

### **Paper Sprinkler Plan Review Submittals**

Paper Plan Review submittals should be mailed to the following address:

**ISO**  
**Plan Review Department**  
**8911 N. Capital of Texas Highway, Suite 2110**  
**Austin, TX 78759**

You may send up to 6 sets to be stamped as reviewed by ISO, but our reviewer keeps one electronic copy of everything you send, so be sure to include an extra set of information for our records.

**Report Turnaround:** The above listed charges for electronic and paper reviews are for a standard 10 business day turnaround. A 3-day service is available at a price of 1.5 the standard rate, and a 1-day service at 2.0 times the standard rate. Please indicate on your transmittal which service you are requesting, **otherwise we will assume you are requesting our 10-business day standard service.**

Please be advised that a state sales tax will be applied based on the laws of the state in which you reside

You may send payment at time of requesting service but since sales tax is applied you may wish to wait for us to send an invoice for the complete amount after we have completed our review.

If you want us to return your review quickly you may want to provide us with your Fed Ex or other mail delivery service account number and we will forward the material according to your directions; otherwise, we send our review back by regular US mail or by UPS.

If you have any questions feel free to call us.

For technical questions, call 512-440-9910

*Saving lives and Protecting Property through Engineering, Enforcement and Education*



**CITY OF ALVIN**  
**Fire Marshal's Office**  
 801 East South Street  
 Alvin, Texas 77511  
 Office (281) 331-7688 FAX (281) 331-9713



## Permit Application – Plans Review and Inspection

Payments made **by check or money order only** payable to the City of Alvin when the approved plans and permit are picked up.

Installing Company Name: \_\_\_\_\_

Installing Company Address: \_\_\_\_\_ Company Phone: \_\_\_\_\_

Address of Installation: \_\_\_\_\_

Business Name (if applicable): \_\_\_\_\_ Business Phone: \_\_\_\_\_

Applicant's Name: \_\_\_\_\_ Applicants Cell Phone: \_\_\_\_\_

Applicant's E-mail Address: \_\_\_\_\_

Applicant's Drivers License #: \_\_\_\_\_ State: \_\_\_\_\_

\_\_\_\_\_  
Signature of Applicant or Authorized Agent

\_\_\_\_\_  
Date

The Applicant or Authorized Agent affirms that all the information contained herein is true and correct to the best of his/her knowledge. This application may be denied or revoked for false statements and/or nonpayment of all fees owed to the City of Alvin.

**Plans Review and Inspection Fees** must be paid prior to any Field Inspection, Hydrostatic Test or Acceptance Testing.  
 The fire code official may impose a **double permit fee** when it is found that a condition, activity or occupancy requiring a permit exist and no permit has been issued by the fire code official.

### TYPE OF PERMIT

**( ) Functional, acceptance, and hydro testing for 20 heads or more, the fee is \$50.00**

#### **FIRE PROTECTION SYSTEMS**

- ( ) Sprinkler System \$60.00 per Riser plus \_\_\_\_\_ heads @ 2.00 per head \_\_\_\_\_
- ( ) Changes to Sprinkler \$75.00 up to 10 heads and 2.00 per head over 10 \_\_\_\_\_
- ( ) Fire Pump \$75.00 \_\_\_\_\_
- ( ) Water storage tank \$100.00 \_\_\_\_\_
- ( ) Jockey Pump \$25.00 \_\_\_\_\_
- ( ) Generator \$100.00 \_\_\_\_\_
- ( ) Fire Alarm System \$75.00 per FACP plus \_\_\_\_\_ devices @ 2.00 per device \_\_\_\_\_
- ( ) Hood Suppression \$100.00 per system plus \_\_\_\_\_ devices @ 2.00 per device \_\_\_\_\_
- ( ) Paint Booth Suppression \$100.00 per System plus \_\_\_\_\_ devices @ 2.00 per device \_\_\_\_\_
- ( ) Underground Fire Line Base permit fee plus hydro fee \_\_\_\_\_

#### **FLAMMABLE & COMBUSTIBLE LIQUIDS**

- ( ) Aboveground storage tank installation \$200.00 \_\_\_\_\_
- ( ) Aboveground tank repair/removal \$50.00 \_\_\_\_\_
- ( ) Underground Storage tank installation \$400.00 \_\_\_\_\_
- ( ) Underground tank repair/removal \$100.00 \_\_\_\_\_

**The base permit fee is \$100.00**

**TOTAL PERMIT FEE \$100.00 base + \_\_\_\_\_**

*Saving lives and Protecting Property through Engineering, Enforcement and Education*



**CITY OF ALVIN**  
**Fire Marshal's Office**  
 801 East South Street  
 Alvin, Texas 77511  
 Office (281) 331-7688 FAX (281) 331-9713



**The following shall be included with  
 FIRE SPRINKLER SYSTEM PLAN SUBMITTAL**

**The sprinkler system shall be constructed with supervisory alarm capability**

Type of Hazard:  Light  Ordinary \_\_\_\_\_  Extra \_\_\_\_\_

Pipe Schedule: \_\_\_\_\_ Hydraulic Calculation: \_\_\_\_\_

Coverage:  Complete  Partial (Specify) \_\_\_\_\_

Light Hazard Locations: \_\_\_\_\_

Ordinary Hazard Locations: \_\_\_\_\_

Extra Hazard Locations: \_\_\_\_\_

Design Area: \_\_\_\_\_

Square Feet of Design Area: \_\_\_\_\_

Most Remote Sprinkler Location: \_\_\_\_\_

Residual Pressure at Highest Sprinkler Location: \_\_\_\_\_ PSI \_\_\_\_\_

Inspector Test Valve Location: \_\_\_\_\_





**CITY OF ALVIN**  
**Fire Marshal's Office**  
 801 East South Street  
 Alvin, Texas 77511  
 Office (281) 331-7688 FAX (281) 331-9713



**SPRINKLER HEADS: (TOTAL)**

Up-rights: TYPE: \_\_\_\_\_ Temp Rating: \_\_\_\_\_

Pendants: TYPE: \_\_\_\_\_ Temp Rating: \_\_\_\_\_

Sidewalls: TYPE: \_\_\_\_\_ Temp Rating: \_\_\_\_\_

Dry Pend: TYPE: \_\_\_\_\_ Temp Rating: \_\_\_\_\_

Other: \_\_\_\_\_

**NOTE: FDC's will require purchase of locking KNOX cap and key wrench**

**ANCILLARY EQUIPMENT**

Alarm Check Valve: YES:  NO:

Flow Alarm: YES:  NO:  WATER:  ELECTRIC:

Tamper Switches: YES:  NO:

Spare Sprinklers: TYPE: \_\_\_\_\_ Quantity: \_\_\_\_\_

TYPE: \_\_\_\_\_ Quantity: \_\_\_\_\_

Additional Appliances Installed: \_\_\_\_\_

\_\_\_\_\_

\_\_\_\_\_



**CITY OF ALVIN**  
**Fire Marshal's Office**  
 801 East South Street  
 Alvin, Texas 77511  
 Office (281) 331-7688 FAX (281) 331-9713



**The following shall be included with  
FIRE ALARM SYSTEM PLAN SUBMITTAL**

Local    Remote    Central Station    Proprietary    Aux.    Other (Specify) \_\_\_\_\_

Monitoring Company: \_\_\_\_\_

License/Certification No: \_\_\_\_\_

Address: \_\_\_\_\_ City \_\_\_\_\_ State \_\_\_\_\_

Phone: \_\_\_\_\_ Other Phone: \_\_\_\_\_

Zone/Coded System:    YES                       NO

Name of Zones: \_\_\_\_\_

Number of Pull Stations: \_\_\_\_\_ Number of Smoke/Heat Detectors: \_\_\_\_\_

Type of Smoke/Heat Detector: \_\_\_\_\_

Coverage:    Complete       Partial (Specify) \_\_\_\_\_

Additional Appliances Installed: \_\_\_\_\_

Meets A.D.A Requirements:    YES       NO

Communication devices for Fire Alarm systems shall be independent and separate from any communication devices used for burglary or panic/hold-up alarms. The only exception is for single-family residences



**CITY OF ALVIN**  
**Fire Marshal's Office**  
 801 East South Street  
 Alvin, Texas 77511  
 Office (281) 331-7688 FAX (281) 331-9713



**The following shall be included with**  
**FIXED FIRE EXTINGUISHING SYSTEM PLAN SUBMITTAL**  
 Hood Suppression, Paint Booth, Spray/Mixing Rooms

Manufacturer: \_\_\_\_\_

Model No.: \_\_\_\_\_

Serial No.: \_\_\_\_\_

Gas valve shall be

UL 300 Approved?     YES         NO

Coverage:         Complete         Partial (Specify) \_\_\_\_\_

\_\_\_\_\_

\_\_\_\_\_

Design Area: \_\_\_\_\_

Other: \_\_\_\_\_

\_\_\_\_\_

**ANCILLARY EQUIPMENT**

Additional Appliances Installed: \_\_\_\_\_

\_\_\_\_\_

\_\_\_\_\_



**CITY OF ALVIN**  
**Fire Marshal's Office**  
 801 East South Street  
 Alvin, Texas 77511  
 Office (281) 331-7688 FAX (281) 331-9713



**SPRINKLER SYSTEM UNDERGROUND CHECKLIST**

BUSINESS NAME: \_\_\_\_\_ DATE: \_\_\_\_\_

ADDRESS: \_\_\_\_\_ PERMIT NUMBER: \_\_\_\_\_

INSTALLER: \_\_\_\_\_ LICENSE NUMBER: \_\_\_\_\_

- Approved set of plans and permit on site.
- Pipe installed per City's requirements, 6" of sand under pipe, 6" on either side, minimum 6" sand on top of pipe, 24" under asphalt or cement.
- Pipe shall be sleeved when through slab.
- All joints, bends and thrust blocks uncovered during hydrostatic test.
- Thrust blocks hardened before hydrostatic test and installed correctly, no cement covering joints, bends, ductile pipe or all thread.
- Hydrostatic test of 200 psi for 2 hours, and bleed pressure after test.
- Flush underground at proper velocity until clean, minimum 10' per second through minimum 4" pipe.
- FDC located within 50' of a fire hydrant, street side, and away from collapse zone.
- FDC shall have a 5" Storz connection unless 13R system, Knox locking cap, at 22.5degree angle, minimum height 18", maximum height 4'.
- FDC shall be a separate line to the riser above the double check.
- No domestic or irrigation taps on calculated fire line.
- Check PIV location with tamper switch installed.
- Double check backflow preventer cannot be in a vault.
- Test paperwork signed and a copy returned to Fire Marshal's Office.

Comments: \_\_\_\_\_

Fire Suppression System Installer: \_\_\_\_\_ Date: \_\_\_\_\_

Fire Inspector: \_\_\_\_\_ Unit No. \_\_\_\_\_ Date: \_\_\_\_\_

*Saving lives and Protecting Property through Engineering, Enforcement and Education*



**CITY OF ALVIN**  
**Fire Marshal's Office**  
 801 East South Street  
 Alvin, Texas 77511  
 Office (281) 331-7688 FAX (281) 331-9713



**SPRINKLER SYSTEM ABOVEGROUND CHECKLIST**

BUSINESS NAME: \_\_\_\_\_ DATE: \_\_\_\_\_  
 ADDRESS: \_\_\_\_\_ PERMIT NUMBER: \_\_\_\_\_  
 INSTALLER: \_\_\_\_\_ LICENSE NUMBER: \_\_\_\_\_

- Approved set of plans and permit on site.
- Pipe hangers properly supporting pipe
- Nothing resting on pipe runs
- Sprinkler heads properly spaced and not obstructed or painted
- Inspectors test in a remote location downstream of water flow alarm and properly labeled
- Hydrostatic test of 200 psi for 2 hours, and bleed pressure after test.
- Flow test activates fire alarm within 90 seconds
- Check tamper switches and activation of supervisory signal on fire alarm panel, include tamper switch on PIV
- Witness main drain test and verify on hydraulic graph chart
- Hydraulic calculation plate installed
- Head box mounted with extra heads and wrenches including Knox cap wrench
- Riser protected by sprinkler head
- Penetrations through fire rated walls sealed properly
- Test paperwork signed and a copy returned to Fire Marshal's Office
- System reset, put in service, and tagged properly

Comments: \_\_\_\_\_  
 \_\_\_\_\_  
 \_\_\_\_\_

Fire Suppression System Installer: \_\_\_\_\_ Date: \_\_\_\_\_



**FIRE DEPARTMENT CONNECTION (FDC)**  
**SIGN DESIGN REQUIREMENTS**

1. Sign shall be constructed from a 15" high by 18" wide metal substrate no thinner than .063.
2. Sign shall have square corners.
3. Background color of the sign shall be "Fire Engine Red" non-reflective.
4. White reflective letters shall be used as set out below.
5. Letter shall be a font comparable to "Folio medium" or "Helvetica medium".
6. Sign shall be permanently attached to a wall directly above fire department connection (FDC) or below freestanding FDC. It shall be 72" from the ground to the bottom of the sign, unless otherwise approved by Fire Marshal.
7. First line (FDC) shall be 6" high letters with 3" between each letter.
8. Second and third lines shall be 2" high with 1/2" spacing between letters.
9. There shall be a 1" margin completely around sign and 1" spacing between lines of text.
10. There shall be 2" spacing between complete words.
11. Second and third line shall have address of building or suite number that system provides for.

**EXAMPLE**

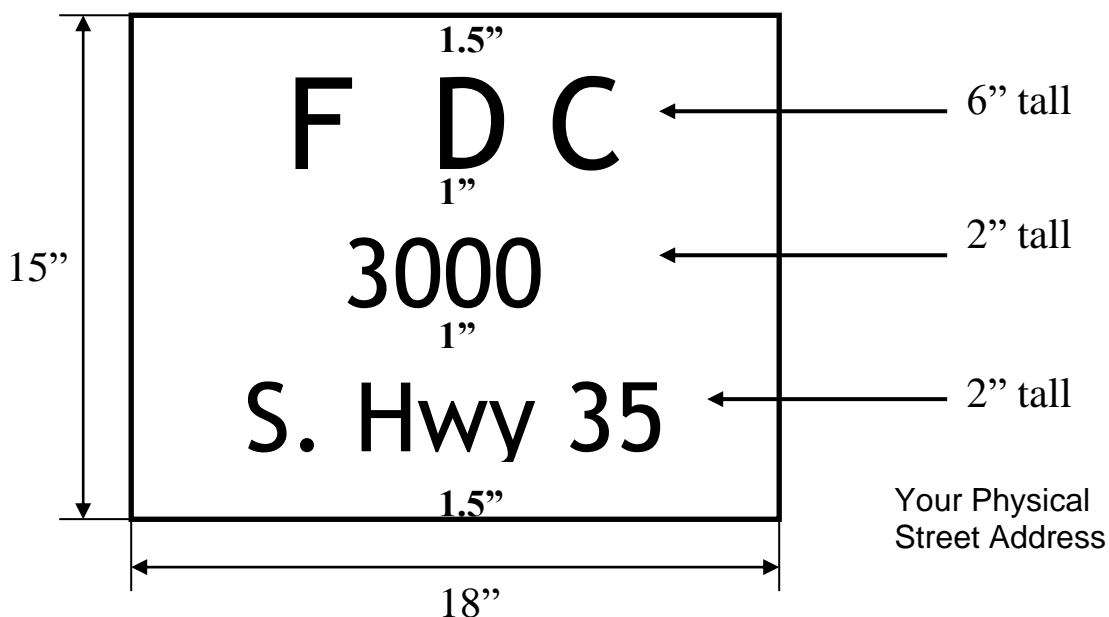





## FIRE LANES

All fire lanes shall be reviewed and approved by the Fire Marshal prior to installation. All fire lanes shall be installed in accordance to the below listed items.

### I. GENERAL GUIDELINES

- 1) All new and existing buildings within the city shall have adequate access for the Fire Department apparatus. The Fire Marshal and building owner/tenant shall designate fire lanes. No building or any type of construction for occupancy shall be constructed in such a manner that any part of the structure is more than one hundred fifty (150) feet from a public street or highway; provided, however, that such structure may be erected at a greater distance if the owner designates, constructs and maintains a fire lane or access easement having a minimum width of twenty (20) feet and a minimum height clearance of thirteen feet six inches (13' 6") terminating within one hundred (100) feet of the farthest point of such structure; provided, further, however, that no fire lane shall be required for any single-family dwelling. In no case shall a fire lane be less than twenty (20) feet in width and have a vertical clearance not less than twenty (20) feet. All fire lanes shall be marked on both sides as a travel lane, including behind parking spaces and dead-end drives.
- 2) All fire lanes shall extend to within one hundred-fifty (150) feet of **all** exterior portions of the facility and exterior walls of the first story of the building as measured by an approved route. (Hose Lay)
- 3) Any fire lane more than one hundred fifty (150) feet in length shall either connect at each end to a dedicated street or be provided with a turnaround having a minimum radius of fifty (50) feet when measured from the centerline of the access roadway to the curb. All fire lanes shall be maintained and kept in a state of good repair at all times by the owner, manager or person in charge of the premises, and the city shall never be responsible for the maintenance thereof.
- 4) All fire lanes shall be posted and marked, and shall be designated as tow away zones by the building owner/tenant. All fire lanes within the city shall be marked using signs, pavement markings or curb markings with the following specifications:
  - a. **Pavement Markings** – All pavement markings shall be installed using red and white traffic paint. The boundaries of the fire lane shall be identified by red stripes at least six (6) inches wide. The words "**FIRE LANE – NO PARKING – TOW AWAY ZONE**" shall appear in four (4) inch white letters at twenty-five (25) foot alternating intervals on the red border markings.
  - b. **Curb Markings** – Curb markings shall be painted in red traffic paint from the top seam of the curb to a point even with the driving surface. The words "**FIRE LANE – NO PARKING – TOW AWAY ZONE**" shall appear in four-inch letters at 25-foot intervals along the curbs
- 5) Signs may be used in lieu pavement markings, as approved. Signs shall conform to the standards listed below and in accordance to City of Alvin ordinance Sec. 9-171.



- a. The owner, manager or person in charge of any building for which fire lanes have been approved by the fire marshal or his authorized representative shall post and maintain appropriate signs in conspicuous places along such fire lanes stating: "No Parking-Fire Lane – Tow Away Zone." Such signs shall be twelve (12) inches wide and eighteen (18) inches high.
- b. Any "No Parking-Fire Lane Tow Away Zone" sign shall be painted on a white background with letters and borders in red. The sign(s) shall be installed such that the bottom of the sign is not less than three (3) feet above grade and the top of the sign is not greater than five (5) feet above grade.
- c. Where the placement of such signs is not applicable or when, in the opinion of the fire marshal or his authorized representative, such signs would cause a burden on the management, curb markings may be used.

**Note: Signs may be installed on permanent buildings or walls or as approved by the Fire Marshal.**

## **II. BUILDINGS EXCEEDING 30 FEET IN HEIGHT**

Fire apparatus access roads for buildings exceeding three stories or thirty (30) feet in height shall be provided with at least three means of fire apparatus access.

## **III. REQUIREMENTS FOR LARGE AREA BUILDINGS**

Buildings exceeding sixty-two thousand (62,000) square feet in area shall provide two separate approved fire apparatus access roads.

**Exception:** Projects with a gross building area up to one hundred twenty-four thousand (124,000) square feet may have a single approved fire apparatus access road when all buildings are equipped with an approved automatic sprinkler system.

## **IV. AERIAL FIRE APPARATUS ACCESS ROADS**

- 1) Buildings or portions of buildings or facilities exceeding 30 feet in height above the lowest level of fire department vehicle access shall be provided with approved fire access roads capable of accommodating fire department aerial apparatus. Overhead utility and power lines shall not be located within the aerial fire apparatus access roadway.
- 2) Fire apparatus access roads shall have a minimum unobstructed width of 26 feet in the immediate vicinity of any building or portion of building more than 30 feet in height.



- 3) At least one of the required access routes meeting this condition shall be located within a minimum of 15 feet and a maximum of 30 feet from the building, and shall be positioned parallel to one entire side of the building.



**DEAD-END FIRE APPARATUS ROAD TURNAROUND**

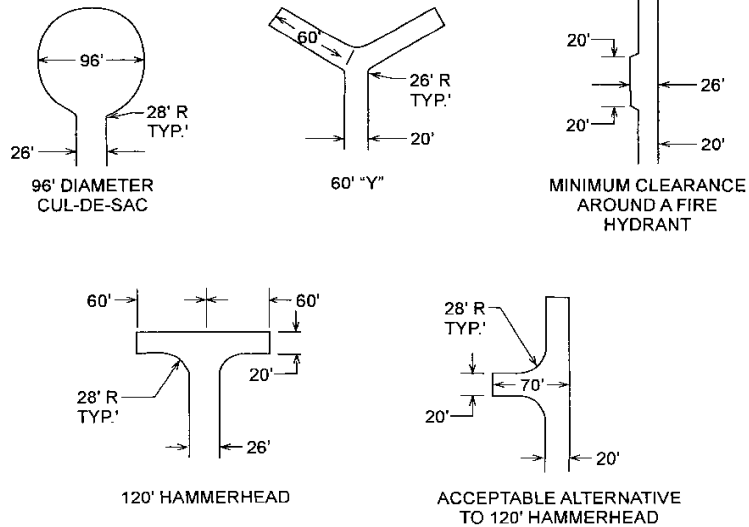



**CITY OF ALVIN**  
**Fire Marshal's Office**  
801 East South Street  
Alvin, Texas 77511  
Office (281) 331-7688 FAX (281) 331-9713



---

### **FIRE ALARM CHECKLIST**

#### **PREMISES TO BE PROTECTED**

Premises Owner: \_\_\_\_\_

Premises Location: \_\_\_\_\_

Owner's Mailing Address: \_\_\_\_\_ State \_\_\_\_\_ Zip \_\_\_\_\_

Owner's Telephone No.: \_\_\_\_\_ Other \_\_\_\_\_

#### **ALARM SYSTEM**

Local  Remote  Central Station  Proprietary  Aux.  Other (Specify) \_\_\_\_\_

NAME OF INSTALLER/COMPANY: \_\_\_\_\_

License/Certification No: \_\_\_\_\_

Company Address: \_\_\_\_\_ City \_\_\_\_\_ State \_\_\_\_\_

Phone: \_\_\_\_\_ Other Phone: \_\_\_\_\_

Zone/Coded System:  YES  NO

Name of Zones: \_\_\_\_\_

Monitoring Company: \_\_\_\_\_

#### **SYSTEM SPECIFICATIONS**

Number of Pull Stations: \_\_\_\_\_ Number of Smoke/Heat Detectors: \_\_\_\_\_

How many Duct Detectors: \_\_\_\_\_ Are they labeled below ceiling:  YES  NO

Type of Smoke/Heat Detector: \_\_\_\_\_

Smoke Detector over FACP and Panel easily found and labeled:  YES  NO

Coverage:  Complete  Partial (Specify) \_\_\_\_\_



**CITY OF ALVIN**  
**Fire Marshal's Office**  
 801 East South Street  
 Alvin, Texas 77511  
 Office (281) 331-7688 FAX (281) 331-9713



Additional Appliances Installed: \_\_\_\_\_

Meets A.D.A Requirements:  YES  NO

**FIRE ALARM CHECKLIST**

**PAGE 2**

MODEL No: \_\_\_\_\_ SERIAL No.: \_\_\_\_\_

PHONE LINE # 1: \_\_\_\_\_ PHONE LINE # 2: \_\_\_\_\_

A/C OPERATION OK?  YES  NO      BATTERY OPERATION OK?  YES  NO

CIRCUIT PANEL LABELED?  YES  NO      NUMBER OF ZONES? \_\_\_\_\_

F.A.C.P. OPERATIONAL?  YES  NO      F.A.C.P. w/DEFAULT PHONE?  YES  NO

TROUBLE ALARM  YES  NO      TAMPER ALARM OK?  YES  NO

FLOW ALARM OK?  YES  NO      HVAC SHUTDOWN  YES  NO

BATTERIES DATED  YES  NO

SEPARATE BUILDINGS ZONED SEPARTELY?  YES  NO

ELEVATOR RECALL OPERATIONAL?  YES  NO

Comments: \_\_\_\_\_

**SYSTEM PASSED TESTING**  YES  NO

Fire Alarm System Installer: \_\_\_\_\_ Date: \_\_\_\_\_

Fire Inspector: \_\_\_\_\_ Unit No. \_\_\_\_\_ Date: \_\_\_\_\_



**CITY OF ALVIN**  
**Fire Marshal's Office**  
 801 East South Street  
 Alvin, Texas 77511  
 Office (281) 331-7688 FAX (281) 331-9713



**COMMERICAL COOKING SUPPRESSION CHECKLIST**

BUSINESS NAME: \_\_\_\_\_ DATE: \_\_\_\_\_  
 ADDRESS: \_\_\_\_\_ PERMIT NUMBER: \_\_\_\_\_  
 INSTALLER: \_\_\_\_\_ LICENSE NUMBER: \_\_\_\_\_

- Approved set of plans and permit on site
- UL 300 wet chemical system
- Provide proper coverage
- Observe activation of system through fuse link cutting
- Observe gas and all electric to shut-off under hood, including lights
- Check nozzle operation by air blow-out test
- Gas shut off valve visible and accessible
- Make up air shut off and exhaust stayed on upon activation
- System tied into fire alarm and zoned correctly, if no building fire alarm a local bell is required
- Hood, duct and ventilation installed properly
- Manual pull in path of exit
- Class K extinguisher and sign within 30 feet of system
- System operated satisfactory
- System was reset and tagged properly

**SYSTEM PASSED TESTING**  YES  NO

Comments: \_\_\_\_\_

Fire Suppression System Installer: \_\_\_\_\_ Date: \_\_\_\_\_

*Saving lives and Protecting Property through Engineering, Enforcement and Education*





**CITY OF ALVIN**  
**Fire Marshal's Office**  
 801 East South Street  
 Alvin, Texas 77511  
 Office (281) 331-7688 FAX (281) 331-9713



Fire Inspector: \_\_\_\_\_ Unit No. \_\_\_\_\_ Date: \_\_\_\_\_

**PAINT BOOTH SUPPRESSION CHECKLIST**

BUSINESS NAME: \_\_\_\_\_ DATE: \_\_\_\_\_

ADDRESS: \_\_\_\_\_ PERMIT NUMBER: \_\_\_\_\_

INSTALLER: \_\_\_\_\_ LICENSE NUMBER: \_\_\_\_\_

- Approved set of plans and permit on site.
- Dry system or special system requirements
- Provide proper coverage
- Observe activation of system through fuse link cutting
- Observe all electric to shut-off in booth, including lights
- Check nozzle operation by air blow-out test
- All air shuts off on activation
- System tied into fire alarm and zoned correctly, if no building fire alarm a local bell is required
- Duct and ventilation installed properly
- Manual pull in path of exit
- Approved fire extinguisher within 75 feet of system
- System operated satisfactory
- System was reset and tagged properly

**SYSTEM PASSED TESTING**

YES  NO

Comments: \_\_\_\_\_

Fire Suppression System Installer: \_\_\_\_\_ Date: \_\_\_\_\_

Fire Inspector: \_\_\_\_\_ Unit No. \_\_\_\_\_ Date: \_\_\_\_\_



**CITY OF ALVIN**  
**Fire Marshal's Office**  
 801 East South Street  
 Alvin, Texas 77511  
 Office (281) 331-7688 FAX (281) 331-9713



**FIRE PUMP CHECKLIST**

BUSINESS NAME: \_\_\_\_\_ DATE: \_\_\_\_\_  
 ADDRESS: \_\_\_\_\_ PERMIT NUMBER: \_\_\_\_\_  
 INSTALLER: \_\_\_\_\_ LICENSE NUMBER: \_\_\_\_\_

- Witness testing of pump at 100% and at 150% of rated capacity for 5 minutes
- Test controller, supervision, and pressure relief
- Check for a dedicated electrical power source and that the electrical connection is before the service connection to the building.
- Alternate power supplies shall be tested according to NFPA 20 and manufacturer specifications. The transfer of power shall take place in the pump room.
- System reset, put in service, and tagged properly

**SYSTEM PASSED TESTING**

YES  NO

Comments: \_\_\_\_\_  
 \_\_\_\_\_

Fire Suppression System Installer: \_\_\_\_\_ Date: \_\_\_\_\_  
 Fire Inspector: \_\_\_\_\_ Unit No. \_\_\_\_\_ Date: \_\_\_\_\_

*Saving lives and Protecting Property through Engineering, Enforcement and Education*



**CITY OF ALVIN**  
**Fire Marshal's Office**  
801 East South Street  
Alvin, Texas 77511  
Office (281) 331-7688 FAX (281) 331-9713



---

## KNOX BOX SIGN DESIGN REQUIREMENTS

1. Sign shall be constructed from a metal substrate no thinner than .063. The size of the sign will depend on the amount of information required.
2. Sign shall have rounded corners.
3. Background color of the sign shall be "Fire Engine Red" non-reflective.
4. White reflective letters shall be used as set out below.
5. Letter shall be a font comparable to "Folio medium" or "Helvetica medium".
6. Sign shall be permanently attached to a wall directly above the Knox Box or where approved by the Fire Marshal or his/her designee.

## EXAMPLES

